



(12) **EUROPEAN PATENT APPLICATION**

(43) Date of publication:  
**11.06.2003 Bulletin 2003/24**

(51) Int Cl.7: **F16B 43/00, F16B 5/02,  
 B25B 23/10**

(21) Application number: **02258374.4**

(22) Date of filing: **04.12.2002**

(84) Designated Contracting States:  
**AT BE BG CH CY CZ DE DK EE ES FI FR GB GR  
 IE IT LI LU MC NL PT SE SI SK TR**  
 Designated Extension States:  
**AL LT LV MK RO SI**

(72) Inventor: **Junkers, John K.**  
**Saddle River, New Jersey 07458 (US)**

(30) Priority: **06.12.2001 US 10377**  
**11.04.2002 US 120343**

(74) Representative: **Hanson, William Bennett**  
**J.Y. & G.W. Johnson,**  
**Kingsbourne House,**  
**229-231 High Holborn**  
**London WC1V 7DP (GB)**

(71) Applicant: **Junkers, John K.**  
**Saddle River, New Jersey 07458 (US)**

(54) **Washer, fastener provided with a washer, and method of and power tool for fastening with the use of the washer**

(57) A washer (6), to be applied between a nut (3) threadingly connected with a bolt (1) which has an axis (A2) and an object (2) including at least two parts to be assembled, has a body (7) having an axis (A1) and is provided with a first bearing face surface (8) located at one axial side and adapted to cooperate with the nut (5), and a second bearing face surface (9) located at an opposite axial side and adapted to cooperate with the ob-

ject (2). At least one third turning resistant surface (10) of the washer (6) is adapted to cooperate with a thread of the bolt (1), so that when the nut (3) is turned with a given torque in one direction and the body (7) of the washer receives simultaneously the given force in an opposite direction, only the nut (3) turns to tighten or loosen the bolt (1) while the body of the washer and the bolt remain rotation stationary. A new method and a new power tool can be employed to use the new washer.

**FIG. 1**

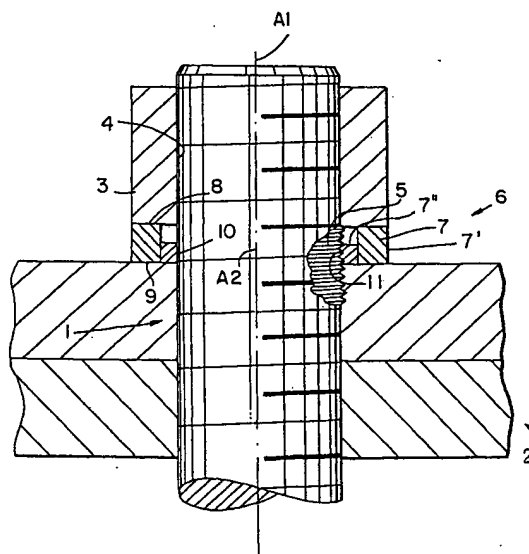

## Description

**[0001]** The present invention relates to a washer, a fastener provided with a washer, and a method of and power tool for fastening with the use of the washer.

**[0002]** It is known to fasten objects to one another with a fastener which has a multi-part replacement nut, for example including an inner sleeve, an outer sleeve, and a washer. Such a replacement nut is disclosed for example in US 5,341,560. Another replacement nut is disclosed in US 6,254,323 in which a bolt has a spline underneath its upper thread, to which a washer is non-rotatably connected, and the bolt also has engaging means for applying a reaction force, while an active force of the same tool turns the nut on the bolt thread and the washer face. In the fastener disclosed in both above mentioned patents, the common features are the use of the action and reaction force of one tool, the elimination of reaction arms on torque power tools, the conversion of torque to torsion-free bolt stretching and obtaining for the first time the desired residual bolt load rather than a torque, which is estimated based on calculated frictions rather than on actual frictions or a tension, which is based on estimated bolt relaxation when the force is transmitted from the elongated bolt to the hand-tight nut.

**[0003]** The problem found in the industry with the fastener disclosed in US 5,341,560 is that, since the nut has to be made with two sleeves whose outside diameter has to meet the outside diameter of a regular nut, both sleeves have less material than a regular nut. This requires the use of high strength materials, which causes reluctance on the part of the customers to change materials and fear of the unknown. In the fastener disclosed in US 6,254,323, the bolt needs to be altered, which is not just costly but not easily acceptable by the industry. In other words, the fastener disclosed in US 5,341,560 requires alteration of the nut, while the fastener disclosed in our US 6,254,323 requires alteration of the bolt. In addition, both versions are expensive to produce, adding to customers' reluctance to purchase these fasteners.

**[0004]** Accordingly, it is an object of the present invention to provide a washer, a fastener provided with a washer, and a method of and a power tool for fastening with the use of the washer, which avoid the disadvantages of the prior art.

**[0005]** In keeping with these objects, one aspect of the present invention provides a washer according to claim 1. The washer has a body having an axis and provided with a first bearing face surface located at one axial side and adapted to cooperate with a nut, and a second bearing face surface located at an opposite axial side and adapted to cooperate with an object. At least one third turning resistant surface of the washer is adapted to cooperate with a thread of the bolt, so that when the nut is turned with a given torque in one direction and said body of the washer receives simultaneous-

ly a given torque in an opposite direction, only the nut turns to tighten or loosen the bolt while the body of the washer and the bolt remain rotation stationary.

**[0006]** Another aspect of the present invention provides a threaded fastener for connecting at least two parts which constitute an object, according to claim 17. The fastener comprises a bolt having a thread and an axis and being introduced into the object; a nut screwable on the bolt; and a washer to be applied between the nut and the object. The washer has a body having an axis and provided with a first bearing face surface located at one axial side and adapted to cooperate with the nut, and a second bearing face surface located at an opposite axial side and adapted to cooperate with the object. At least one third turning resistant surface of the washer is adapted to cooperate with a thread of the bolt, so that when the nut is turned with a given torque in one direction and said body of the washer receives simultaneously a given torque in an opposite direction, only the nut turns to tighten or loosen the bolt while the body of the washer and the bolt remain rotation stationary.

**[0007]** Still another aspect of the present invention provides in a method of assembling at least two parts with one another, according to claim 18. The method comprises the steps of introducing a bolt having a thread into the at least two parts so that a free end of the bolt extends outwardly beyond at least one side of the at least two parts; placing a friction washer on said free end portion of said bolt so that said friction washer engages with said thread of said bolt to create a turning friction between said washer and said bolt and so as to abut against said at least one side of the at least two parts; threadably connecting a nut to said free end portion of said bolt so as to abut against the friction washer and to form an assembly; and placing a torque power tool on the assembly so as to tighten or loosen the nut with a turning portion of said torque power tool connected to the nut to overcome a threaded friction between the bolt and a facial friction with the friction washer to turn the nut, and with a reaction portion of the torque power tool connected to the washer to absorb a reaction force due to a facial friction of the friction washer with the nut, with a facial friction of the washer with said at least one side of the object parts and a turning friction of the bolt selected so that the washer in the bolt do not turn but absorbs the reaction force of the torque power tool.

**[0008]** Still another aspect of the present invention provides a power tool for fastening objects, according to claim 19. The power tool comprises a housing provided with a non-rotatable element; a power drive in said housing and provided with a rotatable driving element; and a fastener part including a bolt having a thread and an axis and introducible into parts forming an object, a nut screwable in said bolt and cooperating with said rotatable driving element, and a washer to be applied between said nut and said object and cooperating with said

non-rotatable element. The washer has an axis and is provided with a first bearing face surface located at one axial side and adapted to cooperate with said nut, a second bearing face surface located at an opposite axial side and adapted to cooperate with said object, and at least one third turning resistant adapted to cooperate with said thread of said bolt, so that when the driving element turns said nut with a given active force in one direction and said washer is held stationarily by a reactive force applied by said non-rotatable element of said housing, only said nut turns to tighten or loosen said bolt, and said washer remains rotation stationary while said bolt elongates or relaxes in an axial direction.

**[0009]** A preferred feature of the present invention is that the third turning resistant surface of the washer increases its turning resistance and/or its resistance toward an axial movement in use according to the increase in drag friction created by the nut onto the bolt when it is under tension, by having the turning resistant surface squeezed further into the bolt thread and against the inside of one of the washer parts as a result of the drag friction of the bolt or the turning force applied to the washer if the given force is applied to it in the opposite direction.

**[0010]** In accordance with another optional feature of the present invention, the turning resistant portion of the washer has for example a ring having an inward side engage in the bolt thread and an outward side having gear teeth to turn a gear engaging in the gear teeth of the ring and also engaging in the inward side of the washer body with two facial friction areas, whereby the gear is connected to a plate between the washer body and the object so that when the bolt turns along with the nut the turning resistant portion of the washer wants to turn along in the same direction, trying to turn the gear, which in turn tries to turn the washer body in the opposite direction to the track friction applied to its bearing face surface by the nut so that the bolt and the washer with its parts remains rotation stationary while the nut is turned.

**[0011]** As the drag friction created by the nut on the bolt can be quite high, the nut in no way diminishes the bolt load resulting from the torque applied to the nut when the bolt stands still. It is the object of the present invention to stop the bolt from turning along with the nut, but to allow the bolt to move in an axial direction when the nut is turned. Therefore, to stop the bolt from turning with or in the third turning resistant surface of the washer when the drag friction is high, a wedge can be inserted between the inner surface of the outer washer part and the outer surface of the inner washer part to increase the turning friction created by the turning resistant surface of the washer with the bolt.

**[0012]** The wedge part can, but does not have to, project above the first bearing surface. When it does project and the nut is turned down on it, the wedge part moves down and wedges the turning resistant surface into the bolt thread to stop all turning of the bolt relative

to it. When it does not project and the turning resistant surface moves up as a result of the turning of the bolt, the upward movement causes it to be pressed against the bolt thread to stop the bolt from turning, in which case it is best located within the two bearing faces of the washer in a way that it also eliminates turning of the turning resistant surface of one washer part relative to the other washer part. Therefore when the bolt turns along the nut and the turning resistant surface arises as a result of it, the turning resistant surface gets squeezed further into the bolt thread, the bolt stops turning as a result of it and the turning resistant surface rises only with the bolt stretch created by the turning nut.

**[0013]** When the washer and the fastener are designed in accordance with the present invention and the method is performed in accordance with the present invention, regular nuts and regular bolts can be used. In other words the customer can use whatever he has adding merely a washer. The benefit is quite remarkable. Firstly, the product is much less expensive than each of the products in the above-mentioned patents. Secondly, the customer uses his approved bolts and nuts. Third, instead of reacting on a part of the nut directly as in US 5,341,560 or indirectly as in US 5,946,789 by passing the reaction force through the washer to a part of the nut, the reaction force is solely absorbed by the washer. Furthermore, the solution proposed in the present application provides the identical benefits as the solutions disclosed in the above mentioned patents, some of which are a torsion-free elongation of the free portion of the bolt, a known coefficient of friction and thus a known bolt load, a reaction-arm free, backup-wrench free and hands free hydraulic torque tool use, and a bridge- and puller-free bolt stretching. In other words, torque is converted into torsion- and side-load-free bolt elongation to the desired bolt load by means of a torque power tool, which can be also applied to torque regular nuts with a reaction member. It needs to be considered that most bolts in the industry are through bolts with a nut on the other side or blind bolts threaded into the bottom part of the two parts.

**[0014]** The holding socket of the power tool, which is connected to the non-rotatable element of the power tool housing, can engage the washer of the invention, for example via a pin between the socket and indents on the hex corner of the washer. The elimination of the reaction arm, usually connected to the motor (cylinder) housing of a torque tool, eliminates the tool's internal torsion, thus making it more reliable. In addition, the operation becomes safer due to the elimination of pinch points because the tool has no reaction arm and does not need to be held against a reaction point during operation, and backup wrenches are no longer required as the bolt and thus the nut on the other side do not turn any longer. In addition, the nut does not scratch or gall the object surface.

**[0015]** It is known that if a torque power tool is applied to a fastener such that the nut is turned by the active

force of the torque power tool and the reaction is absorbed by a regular washer underneath the nut, then either the nut or the washer will turn at will or the bolt turns along with the nut and nothing is accomplished, or the bolt end tightens further into the blind hole causing the bottom threads to mushroom which makes disassembly extremely difficult. The reason for that is that the nut has two friction areas, the threaded connection with the bolt which creates a drag friction and the facial area with the washer, whereby the washer has one facial area with the nut and one facial area with the two parts to be assembled. In other words, both have two friction areas. While it is correct that a threaded friction is a little less than a facial friction, the difference is minute as the facial friction between the washer and the nut balance each other out, so that there is merely one minute difference between the nut and the washer. At the same time if the bolt is a through bolt, the thread friction between the bolt and the nut and thus the bolt turning resistance is obviously much less than the facial friction of the washer and while the washer would absorb the reaction force without turning, the bolt would turn along with the nut and nothing is accomplished unless a back-up wrench is used to stop the bottom nut from turning. Therefore, neither is enough to guarantee that only the nut turns, which is why the third friction area had to be introduced to the washer. This however is not enough to guarantee that only the nut turns.

**[0016]** On the other hand, if the washer in accordance with the present invention is connected with the thread of the bolt, the bolt cannot turn along with the nut because the washer will have to lift up which it cannot because the nut is on top of it. This would make a bolt elongation resulting from turning down the nut impossible. The present invention therefore provides a bolt thread engaging washer section, which is connected with the bolt thread. Since this alone would not help because this section could move either along with the bolt by rotating or upward if the bolt rotates in it. This in turn would allow the bolt to turn along with the nut as the section rotates or moves up. Therefore in accordance with a further new feature of the present invention, the bolt thread engaging means is frictionally connected with the body of the washer, so that its rotational or upward movement is subject to overcoming a friction greater than a drag friction created on the bolt by the turning nut, to stop the bolt from turning. This friction in conjunction with the two facial frictions of the washer assures that the bolt does not move along with the nut, that the bolt is stretched, and that the washer and its bolt thread engaging section do not rotate while the nut is being turned.

**[0017]** It is important to understand that when the bolt turns along with the nut as a result of the drag friction and the bolt thread engagement section turns along with the bolt or moves upward in the washer nothing is accomplished. This explains why either movement of the bolt thread engaging section has to be restricted by requiring a greater force than that exerted by the drag fric-

tion created by the nut onto the bolt even when the bolt is under load. This can be accomplished in various ways as explained by some examples below without limiting the invention.

**[0018]** If the reaction force of the tool is applied to the outside of the washer through engagement means thereon, it is also possible to have a pin or the like connected at one end to the thread engagement section and having its other end sticking out of the circumference of the washer so that when the tool is connected with the washer the pin is pushed inwardly, pushing the thread engagement section inwardly into the bolt thread.

**[0019]** The invention will be best understood from the following description of specific embodiments, given by way of example only, when read in connection with the accompanying drawings, in which:

Figures 1-6 are views of a threaded fastener provided with a washer in accordance with various embodiments of the present invention; and

Figure 7 is a view illustrating a fastening process with the use of the fastener and the washer in accordance with the present invention, and a power tool.

**[0020]** Figures 1 and 2 show a threaded fastener which has a bolt identified with reference numeral 1 and introducible into an object which is composed for example of two parts to be assembled with one another as identified with reference numeral 2. The fastener further has a nut, which is identified with reference numeral 3. The nut is provided with an inner thread 4, which is screwed on an outer thread of the bolt 1.

**[0021]** The threaded fastener further has a washer, which is identified as a whole with reference numeral 6. The washer 6 has a body identified with reference numeral 7 which is provided with a first upper bearing face surface 8 cooperating with the nut 3, a second lower bearing face surface 9 cooperating with the object 2 or in particular with a surface of one of the parts to be assembled with one another, and at least one turning resistant surface which is identified with reference numeral 10. The first and second bearing face surfaces are spaced from one another in an axial direction or in other words in the direction of an axis A1 of the washer which coincides with an axis A2 of the bolt. The at least one third turning resistant surface 10 is located radially inwardly of the body 7 of the washer 6. The third turning resistant surface 10 is formed so as to engage with or wedge in the thread of the bolt 1, for example by providing a corresponding thread 11 on the turning resistant surface 10.

**[0022]** As shown in Figure 1, the body 7 is composed of two parts 7' and 7" which are located radially adjacent to one another, so that the part 7" is located radially inwardly of the part 7'. The turning resistant surface 10 with the bolt thread engaging means 11 is provided ra-

dially inwardly on the part 7". The parts 7' and 7" are connected with one another so as to avoid turning relative to one another, but to permit a movement relative to one another in an axial direction. For this purpose, the portions 7' and 7" can be frictionally connected with one another, for example by being press-fit to create a greater resistance toward movement than the turning force applied by the bolt and so as to stop the bolt from turning along with the nut and permitting an axial movement of the part 7" relative to the part 7' when the bolt is pulled up by the turning nut.

**[0023]** In the embodiment shown in Figure 1a, the turning of the part 7" relative to the part 7' is stopped by interengaging splines 12, for example provided on the radially outer surface of the part 7" and a radially inner surface of the part 7', which permits the axial movement of the part 7" only.

**[0024]** In the embodiment shown in Figure 1b, the turning of the part 7" relative to the part 7' is prevented for example by a key 13 which permits axial movement between the parts 7' and 7" only.

**[0025]** As shown in Figure 2 the part 7" can be for example formed as a split ring, and its radially outward surface can have inwardly rounded pockets 14 extending in the axial direction and can contain pins 15 which are coaxial with the bolt axis and which sit partially in the pockets and abut the radially inward surface of the part 7'. They force the split ring inwardly into the bolt thread if a turning motion is introduced into the part 7' and/or the 7", while limiting the turning between the parts 7' and 7" and also adding a further friction to the movement of the parts 7' and 7" relative to one another in the axial direction.

**[0026]** As shown in Figure 3 the part 7' can have an oval inward surface whose rounded portion has a given dimension, while the part 7" can have at least one ring section engaging the bolt thread and located in the rounded portion by another dimension. Therefore the ring section is forced inwardly into the bolt thread if a turning motion is introduced to the part 7' and/or the part 7" in either direction, while adding restrictions to the movement of the part 7' and the part 7" relative to one another.

**[0027]** In accordance with a further embodiment shown in Figure 3a, the part 7' can be other than round or oval. It can have a shape which is different from the round or oval shapes.

As shown in Figures 4a and 4b, the part 7" can be at least one part which for example has one of its sides banking on the inward surface of the part 7' and formed to restrict the turning motion of the part 7". It has its outer side engaging with the bolt thread and formed with increasing radius relative to the above mentioned one side, so as to turn within its restrictions and thus engage more and more the bolt thread with its outer side, while squeezing more and more with its other side against the inward surface of the part 7' to increase its friction with the part relative to the axial movement of the part 7".

**[0028]** In the embodiment of Figure 4c a pin 16 sits for example on the part 7" and extends outwardly through the part 7' to extend over the outer circumference of the part 7'. Therefore when the engaging means of the tool are connected to the engaging means of the part 7' the pin 16 is pushed inwardly to push the thread engaging sections into the bolt thread, so that the washer can be placed on the bolt without requiring the turning of the washer down the extending bolt threads and so that the axial movement of the thread engaging section is subject to overcoming the friction between it and the pin 16.

**[0029]** In the embodiment of Figures 5a and 5b, the washer is formed so as to stop the bolt and the washer from turning along with the nut when the nut is turned by a power tool. Therefore, a turning resistant portion 7" of the washer 7 comprises for example a ring having an inward side engaging in the bolt thread and an outward side having gear teeth to turn a gear 17 engaging in the gear teeth of the ring and also engaging in the inward side of the washer body with the two facial friction areas. The gear 17 is connected to a plate 17a between the washer body and the object so that when the bolt turns along with the nut, the turning resistant portion of the washer wants to turn in the same direction trying to turn the gear which in turn tries to turn the washer body in the opposite direction to the drag friction applied to its bearing face surface by the nut, so that the bolt and the washer with its parts remains rotation stationary while the nut is turned.

**[0030]** In the embodiment of Figures 6a and 6b the washer is formed so as to stop the bolt from turning in the turning resistant portion of the part 7" by providing at least one wedge-shaped part 18 between the parts 7' and 7". It stops the part 7" from turning in the part 7' so that the drag force of the turning bolt can only raise the turning resistant portion of the washer which, however, wedges it further into the bolt thread until the bolt stops turning and the turning resistant surface moves only axially with the bolt.

**[0031]** The lower bearing face surface 9 of the body of the washer can be formed to have a high friction relative to the object, for example, roughened.

**[0032]** In accordance with the invention, it is also possible that the bolt thread engaging means has a different angle than a thread of the bolt, to create a greater friction between it and the bolt thread. It is also possible that the bolt thread engaging means is not threaded, but has a surface softer than a surface of the bolt to cause friction.

**[0033]** Figure 7 shows a power tool in accordance with the present invention. The power tool can be electrically driven, pneumatically driven, hydraulically driven, or manually driven. It has a power tool part with a housing identified as a whole with reference numeral 20, and a power drive in the housing and identified with reference numeral 21. The power tool part further has a rotatable driving element 22 which is to be connected to

a nut of a fastener and turn the nut to overcome a thread friction with a bolt and a facial friction with a washer to turn the nut, and a non-rotatable element 23 connectable to a washer to absorb the reaction force due to the facial friction of the washer with the nut, its facial friction with one side of two parts to be fastened with one another, and its turning friction with the bolt, so that the washer and the bolt do not turn but absorb the reaction force of the power tool.

[0034] The power drive of the power tool part can include a cylinder 24, a piston 25 reciprocatingly movable in the cylinder under the action of a working fluid medium, a piston rod 26 extending outwardly beyond the cylinder 24 and pivotably connected with at least one driving plate 27 which carries a not shown pawl engaged with a ratchet 28 so as to form a pawl ratchet mechanism, with the ratchet being turnable and connected with the rotatable driving element 22, while the non-rotatable element 23 is fixedly connected with the housing.

[0035] When as shown in Figure 7 the power tool part is placed on the fastener so as to tighten or loosen the nut 5, the working fluid medium in the cylinder 24 displaces the piston 25 which in turn through the pawl-ratchet mechanism turns the ratchet 28, and as a result the rotatable driving element 22 which is connected to the nut 5 turns the nut to overcome the thread friction with the bolt 1 and the facial friction with the washer 6, while the non-rotatable element 23 which is immovably connected to the housing is connected to the washer 6 to absorb the reaction force due to the facial friction of the washer 6 with the nut 5, its facial friction with one side of the parts 2, and its turning friction with the bolt 1, so that the washer 6 and the bolt 1 do not turn, but absorb the reaction force. During the operation of the inventive power tool, the action force is applied to the nut 5, and the equal reaction force is applied to the washer 6.

[0036] It is to be understood that in order to engage the nut 5 by the turning part 22 of the torque power tool 21, the nut must have corresponding connecting means formed, for example as a polygonal shape of the outer surface of the nut, as splines provided on the outer surface of the nut, etc. On the other hand, in order to connect the reaction portion 23 of the torque power tool 21 to the washer 6, the washer also must be provided with connecting means formed for example also as a polygonal outer surface of the washer, as a plurality of splines of the outer surface of the washer, etc.

[0037] It will be understood that each of the elements described above, or two or more together, may also find a useful application in other types of constructions differing from the types described above.

[0038] While the invention has been illustrated and described as embodied in washer, fastener provided with a washer, and method of and a tool for fastening with the use of the washer, it is not intended to be limited to the details shown, since modifications and structural changes may be made without departing in any way

from the present invention as defined by the appended claims.

## 5 Claims

1. A washer (6) to be applied between a nut (5) threadingly connected with a bolt (1) which has an axis (A2) and an object (2) including at least two parts to be assembled, the washer comprising a body (7) having an axis (A1) and provided with a first bearing face surface (8) located at one axial side and adapted to cooperate with the nut (5), and a second bearing face surface (9) located at an opposite axial side and adapted to cooperate with the object (2), **characterised by** at least one third turning resistant surface (10) adapted to cooperate with a thread of the bolt (1), so that when the nut (5) is turned with a given torque in one direction and said body of the washer (6) receives simultaneously a given torque in an opposite direction, only the nut (5) turns to tighten or loosen the bolt (1) while said body of the washer (6) and the bolt remain rotation stationary.
2. A washer as defined in claim 1, further comprising a bolt thread engaging means (11) which is formed on said at least one third turning resistant surface (10) of said body (7) to engage the thread of the bolt (1) and is frictionally connected with said body.
3. A washer as defined in claim 2, wherein said at least one third turning resistant surface (10) is a radially inner surface of said body (7) which is coaxial with said axis (A1) of said body and is provided with said bolt thread engaging means (11).
4. A washer as defined in claim 2 or 3, wherein said body (7) is composed of two parts (7', 7'') which are arranged radially near one another and include a radially inner part (7'') and a radially outer part (7'), said bolt thread engaging means (11) being provided on said inner part (7''), said parts being formed so that they are not freely rotatable relative to one another but are axially displaceable relative to one another.
5. A washer as defined in claim 4, further comprising means for pressing and wedging said thread engaging means (11) in the bolt thread during turning of the nut (5) and including inclined surface means (15) provided on one of said parts (7', 7'') and acted upon during turning of the nut (5) so as to press said inner part (7'') in a radially inward direction toward the bolt (1).
6. A washer as defined in claim 5, further comprising pin means (14) arranged between said parts (7', 7'') and acting on said inclined surface means (15) to

- press said inner part (7") in a radially inward direction toward the bolt (1).
7. A washer as defined in claim 4, 5 or 6, further comprising means for connecting said parts (7', 7") with one another so that they are not freely rotatable relative to one another but axially movable relative to one another, said connecting means including a plurality of splines (12) provided on said parts and engaging with one another.
8. A washer as defined in claim 4, 5 or 6, further comprising means for connecting said parts (7', 7") with one another so that they are not freely rotatable relative to one another but axially movable relative to one another, said connecting means including means for press fitting said parts with one another.
9. A washer as defined in claim 4, 5 or 6, further comprising means for connecting said parts (7', 7") so that they are not freely rotatable relative to one another but axially movable relative to one another, said connecting means including key means (13) provided between said parts.
10. A washer as defined in claim 4, 5 or 6, wherein at least one of said parts (7', 7") has a non-round surface facing the other of said parts and cooperating with said other part so that said parts (7', 7") are not freely rotatable relative to one another but axially movable relative to one another.
11. A washer as defined in claim 4, 5 or 6, wherein at least one of said parts (7', 7") has a cross-section which cooperates of the other of said parts so that said parts (7', 7") are not freely rotatable relative to one another but axially movable relative to one another.
12. A washer as defined in claim 4, further comprising means (16) for pressing said inner part (7") toward the thread of the bolt (1) and movable between an inoperative position in which it does not press said inner part toward the thread of the bolt and an operative position in which it is displaced by an outside tool toward said inner part (7") so as to press said inner part toward the thread of the bolt (1).
13. A washer as defined in claim 4, 5, 6 or 12, further comprising connecting means (17) for connecting said parts (7', 7") with one another so that they are not freely rotatable relative to one another but axially movable relative to one another, said connecting means including ring gear means (17) engaging with both said parts.
14. A washer as defined in claim 13, wherein said gear means (17) is provided with plate means (17a) adapted to be located between said body (7) and the object (2).
15. A washer as defined in claim 4, 5, 6 or 13, further comprising means (18) for connecting said parts with one another so that they are not freely rotatable relative to one another but axially movable relative to one another; said connecting means including wedge means (18) provided between said parts.
16. A washer as defined in any preceding claim, wherein said second bearing face surface (9) is formed so as to have a high friction relative to the object (2).
17. A threaded fastener for connecting at least two parts which constitute an object (2), comprising a bolt (1) having a thread and an axis (A2) and introducible into the at least two parts forming an object; a nut (5) screwable on said bolt; and a washer (6) to be applied between said nut (5) and said object (2), said washer having an axis (A1) and being provided with a first bearing face surface (8) located at one axial side and adapted to cooperate with said nut (5), and a second bearing face surface (9) located at an opposite axial side and adapted to cooperate with said object (2), **characterised in that** said washer (6) has at least one third turning resistant surface (10) adapted to cooperate with said thread of said bolt (1), so that when said nut (5) is turned with a given torque in one direction and said washer (6) receives simultaneously a given torque in an opposite direction, only said nut turns to tighten or loosen said bolt (1) while said washer and said bolt remain rotation stationary.
18. A method of assembling at least two parts with one another, comprising the steps of introducing a bolt (1) having a thread and an axis (A2) into the at least two parts so that a free end portion of the bolt (1) extends outwardly beyond at least one side of said parts; placing a friction washer (6) on said free end portion of said bolt so that said friction washer engages with said thread of said bolt (1) to create a turning friction between said washer (6) and said bolt and so as to abut against said at least one side of the at least two parts; threadably connecting a nut (5) to said free end portion of said bolt (1) so as to abut against the friction washer (6) and to form an assembly; and placing a torque power tool on the assembly so as to tighten or loosen the nut with a turning portion (22) of said torque power tool connected to the nut (5) to overcome a threaded friction between the bolt (1) and a facial friction with the friction washer (6) to turn the nut, and with a reaction portion (23) of the torque power tool connected to the washer to absorb a reaction force due to a facial friction of the friction washer (6) with the nut (5), with a facial friction of the washer with said at least one

side of said at least two parts and a turning friction of the bolt (1) selected so that the washer (6) and the bolt do not turn but absorb the reaction force of the torque power tool.

5

19. A power tool for fastening objects, comprising a housing (20) provided with a non-rotatable element (23); a power drive (21) in said housing and provided with a rotatable driving element (22); and a fastener part including a bolt (1) having a thread and an axis (A2) and introducible into parts forming an object (2), a nut (5) screwable on said bolt (1) and cooperating with said rotatable driving element (22), and a washer (6) according to any one of claims 1 to 16.

10

15

20. A power tool as defined in claim 19, wherein said tool has a turning mechanism (27, 28), said driving element (22) being formed as a projection which is connected with said turning mechanism and is turned by the latter.

20

25

30

35

40

45

50

55



FIG. 1

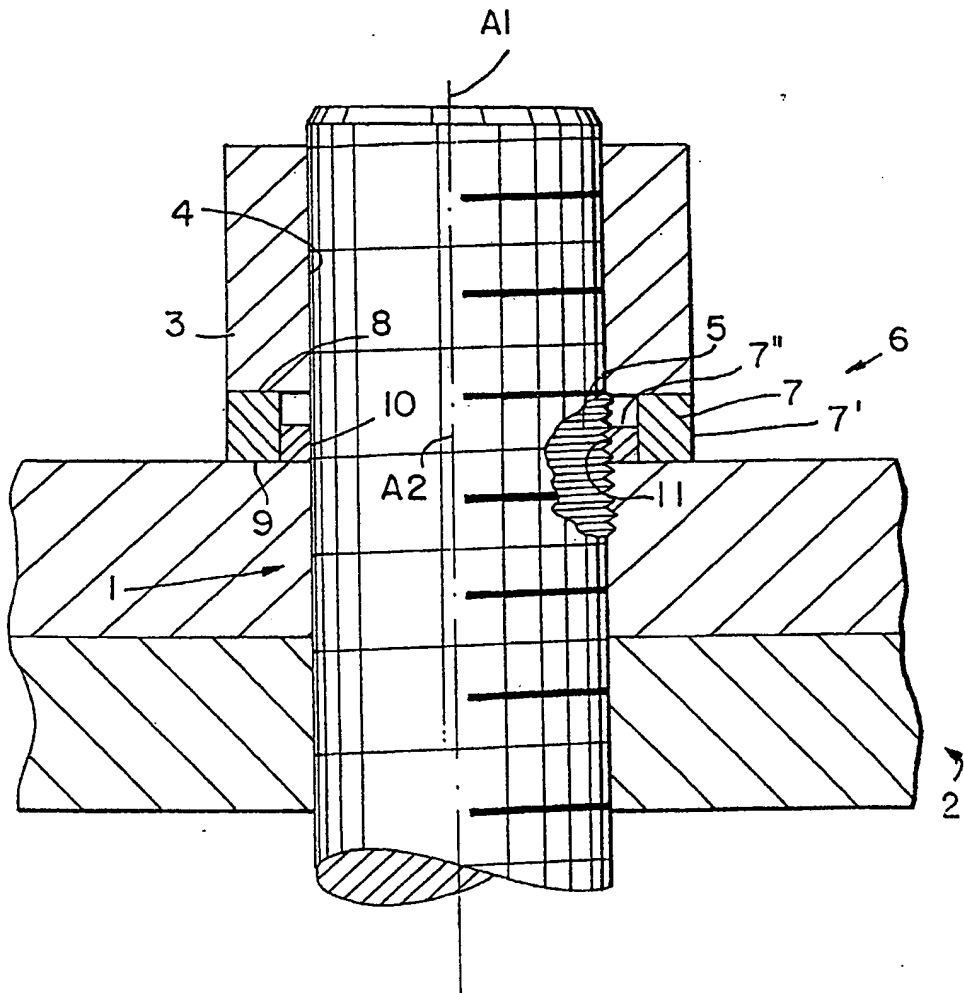

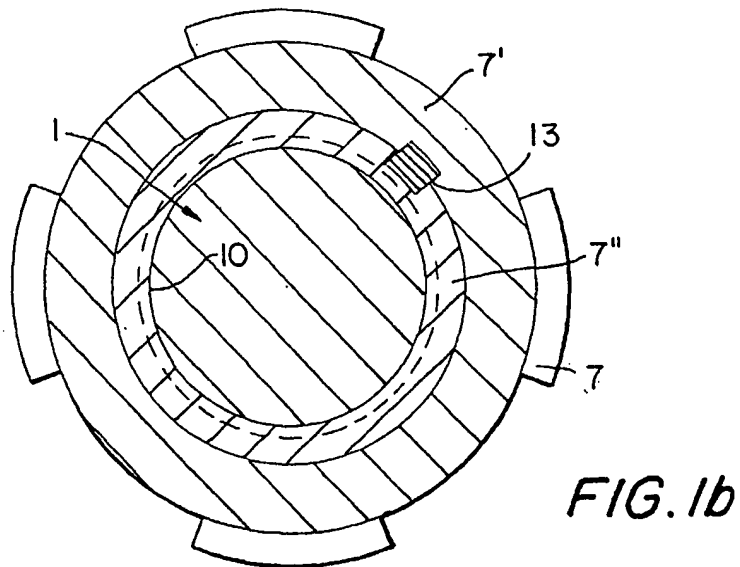
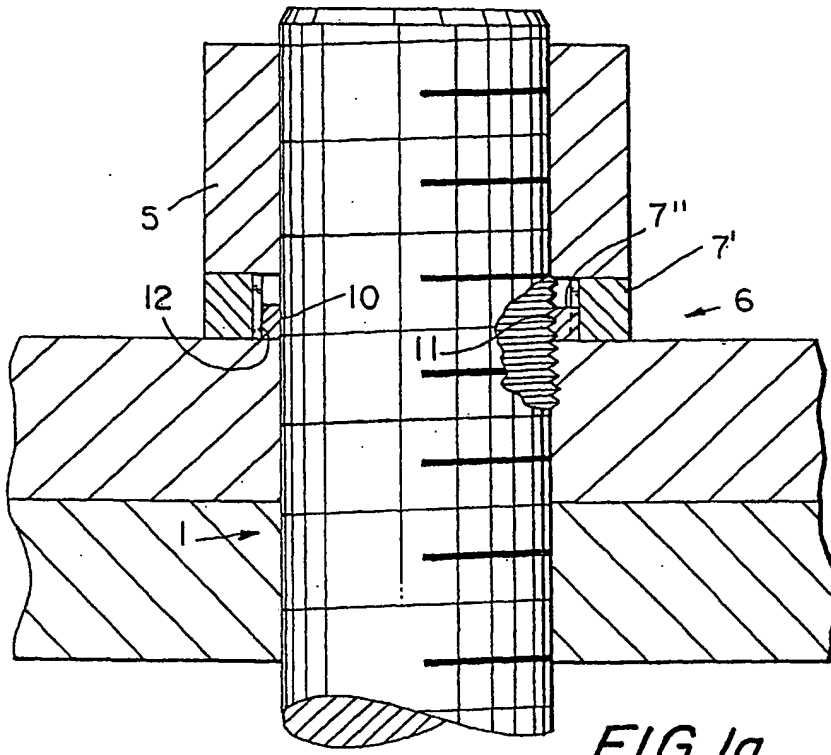

FIG. 2

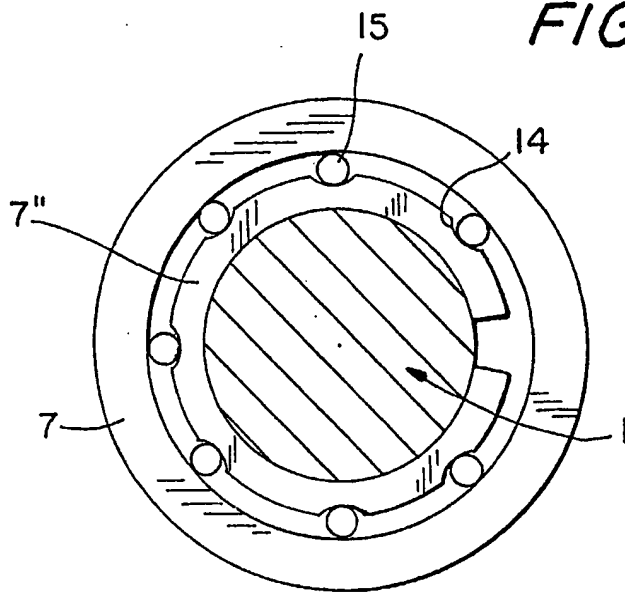

FIG. 3

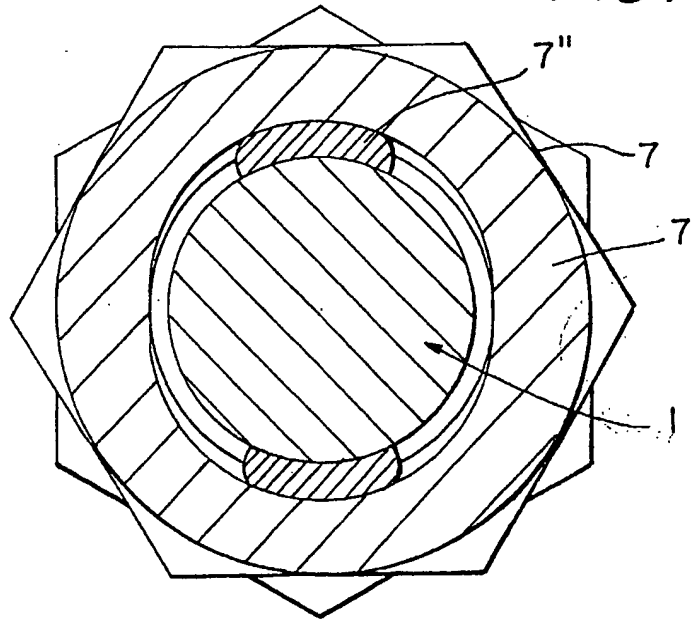

FIG. 3a

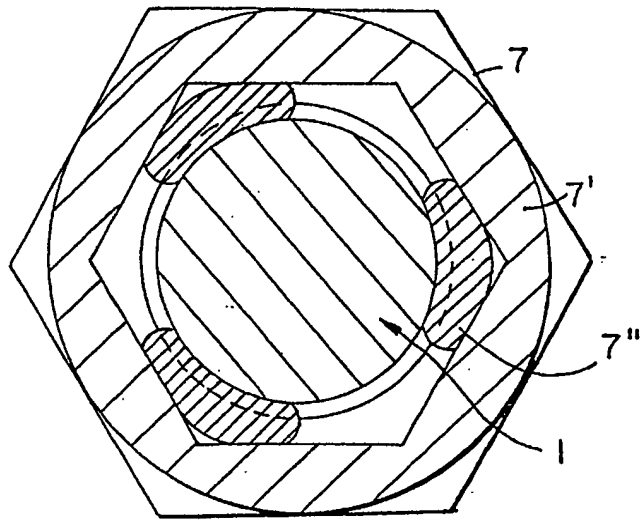

FIG. 4a

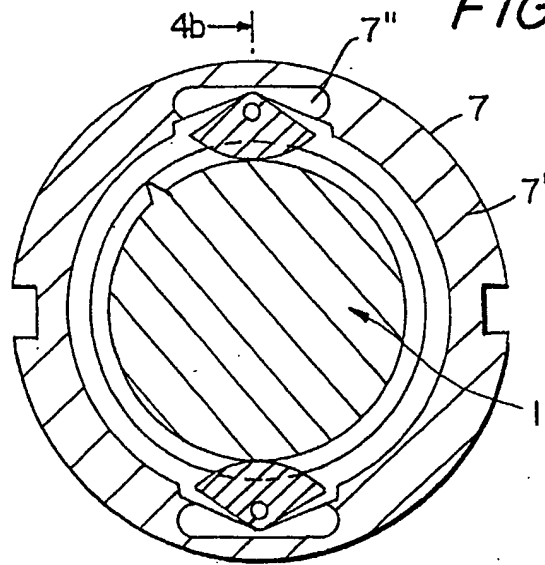

FIG. 4b

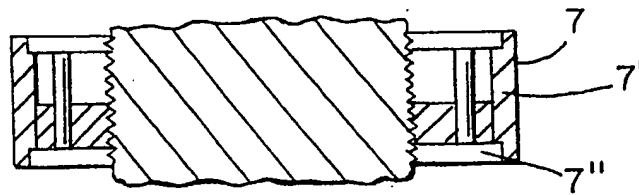

FIG. 4c

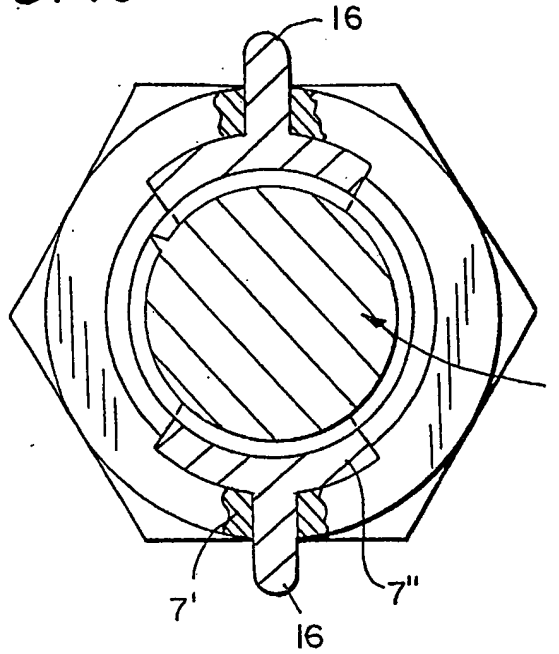

FIG. 5a

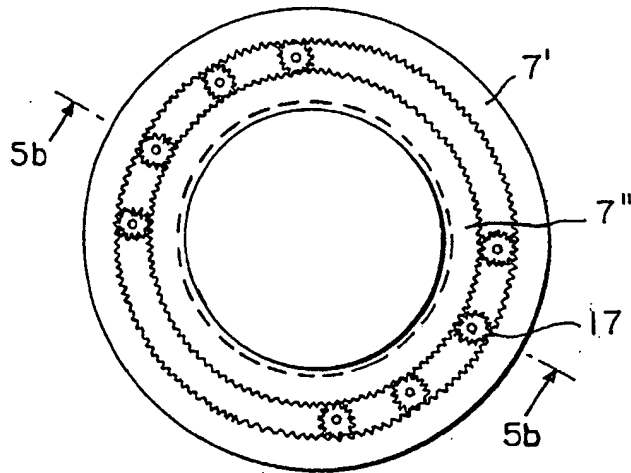

FIG. 5b

